

MERITOR® TIRE INFLATION SYSTEM (MTIS) BY PSI™ INCLUDING MERITOR THERMALERT™

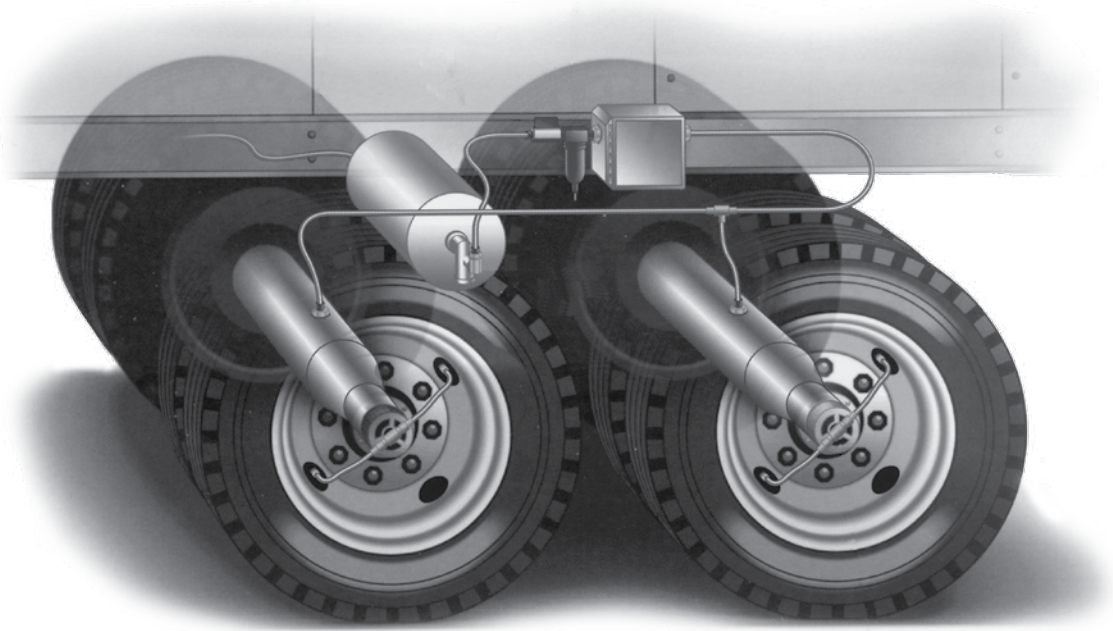

TABLE OF CONTENTS

Repair Kits and Components Page

Control Box.....	4
Hoses	6
Hub Caps	7
Light	4
Press Plug Kits	6
Retrofit Kits	3
Through-Tees and Stators	5
Tools	8
Exploded Views	2
Numerical Parts Listing	11

PB-9999

Revised 05/11



CONTROL BOX ASSEMBLY

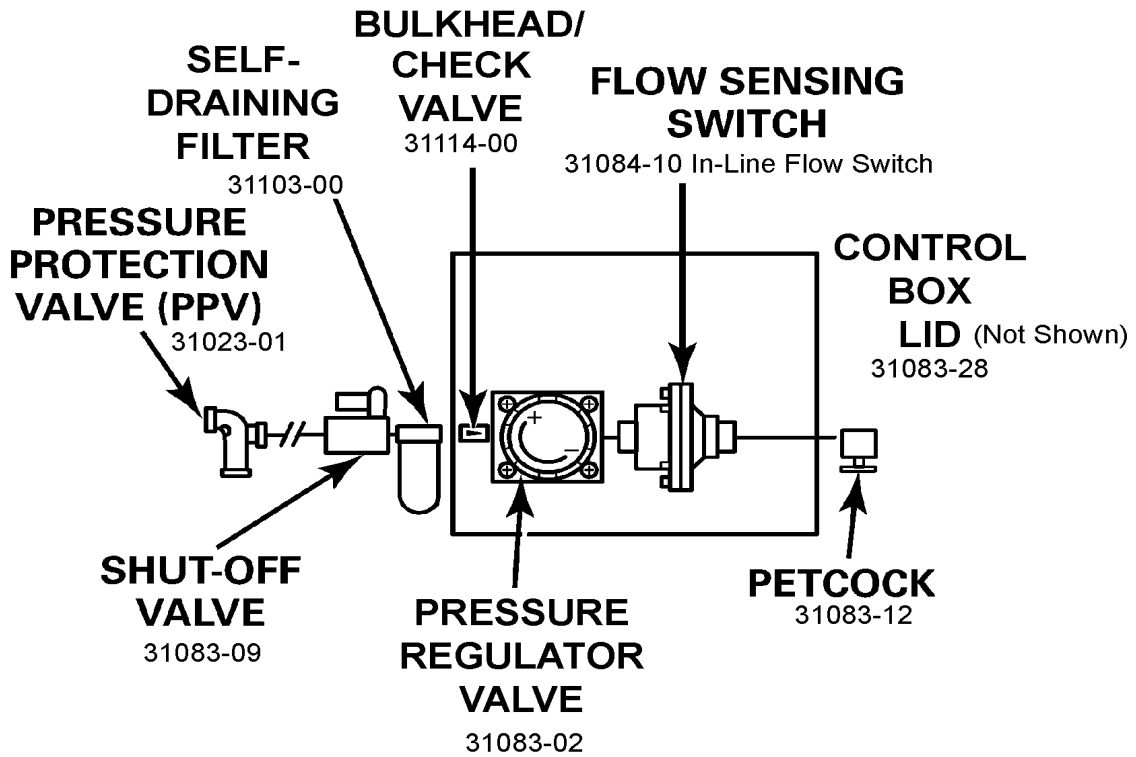

DUAL WHEEL-END ASSEMBLY

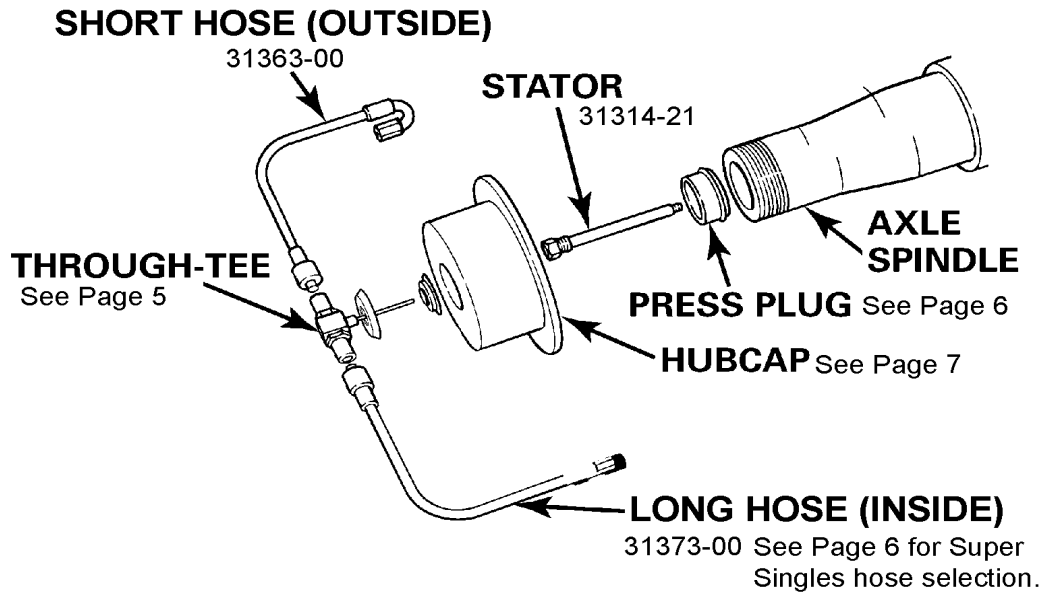

Meritor Tire Inflation System Retrofit Kits

	Qty. Per Tandem Kit	Components
	1	Control box with lid
	1	Control box bracket
	Bulk	Air tubing
	Bulk	Electrical cable
	Bulk	Nylon tie straps
	1	Trailer light with hardware
	4	Through-tees with flappers and shields
	4	Stators
	4	Press plugs with adhesive and towlettes
4	Flex hoses for inside tire	
4	Flex hoses for outside tire	
1	Pressure protection valve	
1	Miscellaneous fitting and hardware kit	

How to Specify Retrofit Kits:

- Determine axle manufacturer and spindle style - straight or tapered. If the axle was MTIS prepped at factory, use MTIS Prepped Kit (less press plugs and stators).
- Identify wheel size and determine axle count. Use the charts below to select the correct retrofit kit.
- See Page 7 to select the appropriate style of hubcaps (hubcaps included in full ThermALERT™ kits).

NOTE: All retrofit kits are pre-set to 100psi. Please consult the MTIS Maintenance and Installation Manual (MM14P) for additional details.

Retrofit Kit Series:

• Straight Spindle

- 31955 Series Holland Propar
- 31975 Series Meritor TP, TB (1998 and later), WP, Hendrickson HP - 2.75"
- H1975 Series ThermALERT™ for Meritor TP, TB (1998 and later), WP, Hendrickson HP - 2.75"
- 32405 Series Meritor TB (before 1998) - 2.95"
- 32595 Series Sudisa 12-R
- 32815 Series Dana P22, Hendrickson HP - 2.50"
- 61151 Series Meritor TL

• Tapered Spindle

- 31924 Series Dana/Eaton D22 Solid Spindle (See Page 8 for Drill Jig details)
- 31935 Series Ingersol F22
- 31965 Series Meritor TN/TQ, RN/RQ, Hendrickson HN, Dana/Eaton D22 Hollow Spindle
- H1965 Series ThermALERT™ for Meritor TN/TQ, RN/RQ, Hendrickson HN, Dana/Eaton D22 Hollow Spindle
- 32375 Series Holland Trade
- 32645 Series Sudisa 11-M

• MTIS Prepped Axles

- 32712 Series All Manufacturers (does not include Press Plugs and Stators)
- H2712 Series ThermALERT™ for All Manufacturers (does not include ThermALERT™ Press Plugs and Stators)

MTIS Retrofit Kit Part Number Designation:

31965 - 22 S - 17







<p>Series Axle Mfg/Spindle Type</p> <p>Axle Count 11 = Single Axle 22 = Tandem Axle 33 = Tri-Axle 44 = Quad-Axle</p>	<p>Only used if axle is equipped with Super Single Tires.</p>	<p>Hubcap Suffix for ThermALERT™ Kits</p> <table border="0"> <tr> <td>D1 Dual Dynamics 6H, 5.5" oil</td> <td>S1 Stemco 6H, 5.5" oil</td> </tr> <tr> <td>D2 Dual Dynamics 6H, 5.5" grease</td> <td>S2 Stemco 6H, 5.5" grease</td> </tr> <tr> <td>D3 Dual Dynamics screw-on oil</td> <td>S3 Stemco screw-on oil</td> </tr> <tr> <td>D4 Dual Dynamics screw-on grease</td> <td>S4 Stemco screw-on grease</td> </tr> <tr> <td>D5 Dual Dynamics 6H, 6.75" oil</td> <td>S5 Stemco 6H, 6.75" oil</td> </tr> <tr> <td>D6 Dual Dynamics 6H, 6.75" grease</td> <td>S6 Stemco 6H, 6.75" grease</td> </tr> </table> <p>Also used if wheel size is 17.50" or smaller</p>	D1 Dual Dynamics 6H, 5.5" oil	S1 Stemco 6H, 5.5" oil	D2 Dual Dynamics 6H, 5.5" grease	S2 Stemco 6H, 5.5" grease	D3 Dual Dynamics screw-on oil	S3 Stemco screw-on oil	D4 Dual Dynamics screw-on grease	S4 Stemco screw-on grease	D5 Dual Dynamics 6H, 6.75" oil	S5 Stemco 6H, 6.75" oil	D6 Dual Dynamics 6H, 6.75" grease	S6 Stemco 6H, 6.75" grease
D1 Dual Dynamics 6H, 5.5" oil	S1 Stemco 6H, 5.5" oil													
D2 Dual Dynamics 6H, 5.5" grease	S2 Stemco 6H, 5.5" grease													
D3 Dual Dynamics screw-on oil	S3 Stemco screw-on oil													
D4 Dual Dynamics screw-on grease	S4 Stemco screw-on grease													
D5 Dual Dynamics 6H, 6.75" oil	S5 Stemco 6H, 6.75" oil													
D6 Dual Dynamics 6H, 6.75" grease	S6 Stemco 6H, 6.75" grease													

For 5 Axle Trailers: Use 1 Quad-Axle Kit and 1 Single Axle Kit or 1 Tri-Axle Kit and 1 Tandem Axle Kit.





Meritor Tire Inflation System Components

	Part Number	Description
	31023-01	Primary Pressure Protection Valve Assembly
	31052-35	1/4" Tubing, 35 Feet.
	31082-00	Control Box Assembly (includes Primary In-Line Filter). ThermAlert ready. Replaces 31084-00 which cannot be used on ThermAlert Systems. For exploded view and components, see Page 2.
	31083-28	Lid only.
	31263-08	Light only. (Not for ThermALERT system)
	31263-06	Light, Bracket and Hardware.
	31263-03	Bracket only.
	31263-14	LED Lamp for ThermALERT
	31263-15	LED Bracket for ThermALERT
	31263-16	LED Pigtail for ThermALERT
	31103-00	Control Box Self-Draining Filter.
	31083-09	Control Box Shut-Off Valve.
	31083-02	Control Box Pressure Regulator Valve.
	31114-00	Control Box Bulkhead/Check Valve.
	31084-10	Control Box Flow Sensing Switch - In-Line. ThermALERT ready. Color Gray. Replaces 31084-03 which cannot be used on ThermALERT systems.

Meritor Tire Inflation System Components

	Part Number	Tube Length	Description
	31314-21	---	Stator & Filter Assembly (1/4" NPT). Threads into spindle plug.
	31317-03	3.50 "	Brass Thru-Tee Assembly with Tee Vent and Shield. Stainless steel tube. For Dual Tire Applications. Replaces 31315-03, 31316-03.
	31317-00	4.25"	Brass Thru-Tee Assy. with Tee Vent and Shield. Stainless steel tube. Replaces 31316-00.
	31317-04	6.25"	Brass Thru-Tee Assembly with Tee Vent and Shield. Stainless steel tube. For use with Dual Tire Propar Axles. Replaces 31315-04, 31316-04.
	31317-03-S	3.50 "	Brass Thru-Tee Assembly with Tee Vent and Shield. Stainless steel tube. For Super Single Tire Applications. Replaces 31315-03-S, 31316-03-S.
	31317-00-S	4.25"	Brass Thru-Tee Assembly with Tee Vent and Shield. Stainless steel tube. For Super Single Tire Applications.
	31317-04-S	6.25"	Brass Thru-Tee Assembly with Tee Vent and Shield. Stainless steel tube. For Super Single Tire Applications.

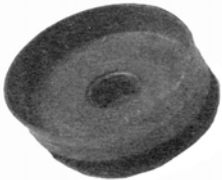
Meritor Tire Inflation System Components

	Part Number	Description
	31363-00	Short Flex Hose (Outside Tire). For wheels larger than 17.50".
	31364-00	For wheels 17.50" or smaller.
	31373-00	Long Flex Hose (Inside Tire). For wheels larger than 17.50". Also for use with Super Single tires.
	31374-00	For wheels 17.50" or smaller. Also for use with Super Single tires.
	31982-01	Small Parts Assortment. Contains: Pressure Protection Valve 1/4" NPT x 1/4" TBG 90° Fitting 3/8" Hex Nipple 1/8" x 1/4" TBG Compression 5/16" Hex Head Capscrew 5/16" Self Locking Hex Nut 1/4" Flat Washer 1/4" Locknut 1/4" TBG Union Tee
	32701-01A	1.50" Press Plug Kit with O-Ring. Includes Adhesive. Used in Ingersol F22
	32611-01A	1.50" Press Plug Kit with O-Ring. Includes Adhesive. Used in Sudisa 11M
	32202-01A	1.75" Press Plug Kit with O-Ring. Includes Adhesive. Used in Meritor TN/TQ, RN/RQ, Hendrickson HN, Dana/Eaton D22 Hollow Spindle
	32342-01A	1.86" Press Plug Kit with O-Ring. Includes Adhesive. Used in Holland Trade
	32473-01A	2.50" Press Plug Kit with O-Ring. Includes Adhesive. Used in Dana P22, Hendrickson HP (Pre 2002)
	32184-01A	2.75" Press Plug Kit with O-Ring. Includes Adhesive. Used in Meritor TP, TB, WP, Hendrickson HP (After 2002)
	32382-01A	2.95" Press Plug Kit with O-Ring. Includes Adhesive. Used in Meritor TB Axles with Large Spindle Bore.
	61021-01A	Press Plug Kit with O-Ring. Includes Adhesive. Used in Meritor TL Axles
	32601-01A	2.25" Press Plug Kit with O-Ring. Includes Adhesive. Used in Sudisa 12R
	32321-01A	2.75" Press Plug Kit with O-Ring. Includes Adhesive. Used in Holland Propar
	32271-01	Press Plug Kit with O-Ring. Includes Adhesive. Used in Sudisa 9M Axle
	H2200-02	ThermALERT Thermal Plug Kit

Hubcaps



Part Number	Manufacturer	Bolt Holes	Bolt Circle	Type	Description
31427-00	Stemco	6	5.50"	Oil	Stemco hubcap version 4009 (343-4370). Six vent design. Replaces three vent design part number 31422-00.
31426-00	Stemco	6	5.50"	Grease	Stemco hubcap version 4009 (340-4370). Six vent design. Replaces three vent design part number 31423-00.
31428-00	Stemco	6	6.375"	Grease	Stemco hubcap (340-4384). Six vent design. For Meritor TL Axles.
31438-00	Stemco	screw-on		Oil	Stemco hubcap version 4075 (343-4371). Straight spindle. Six vent design. Replaces three vent design part number 31432-00.
31436-00	Stemco	screw-on		Grease	Stemco hubcap version 4075 (340-4371). Straight spindle. Six vent design. Replaces three vent design part number 31433-00.
31439-00	Stemco	6	6.75"	Oil	Stemco hubcap version 4195 (343-4372). Straight spindle used with steel hubs only. Six vent design. Replaces three vent design part number 31434-00.
31437-00	Stemco	6	6.75"	Grease	Stemco hubcap version 4195 (340-4372). Straight spindle used with steel hubs only. Six vent design. Replaces three vent design part number 31435-00.
32273-00	Dual Dynamics	6	5.50"	Grease	Dual Dynamics hubcap version 401-G. Six vent design. Replaces three vent design part number 32272-00.
32283-00	Dual Dynamics	6	5.50"	Oil	Dual Dynamics hubcap version 207P6. Six vent design. Replaces three vent design part number 32282-00.
32293-00	Dual Dynamics	screw-on		Grease	Dual Dynamics hubcap version 269G6. Six vent design. Straight spindle. Replaces three vent design part number 32292-00.
32295-00	Dual Dynamics	screw-on		Oil	Dual Dynamics hubcap version 267P6. Straight spindle. Six vent design. Replaces three vent design part number 32294-00.
32514-00	Dual Dynamics	6	6.75"	Grease	Dual Dynamics hubcap version 456G6. Six vent design. Replaces three vent design part number 32512-00.
32515-00	Dual Dynamics	6	6.75"	Oil	Dual Dynamics hubcap version 260P6. Six vent design. Replaces three vent design part number 32513-00.

Meritor Tire Inflation System Components

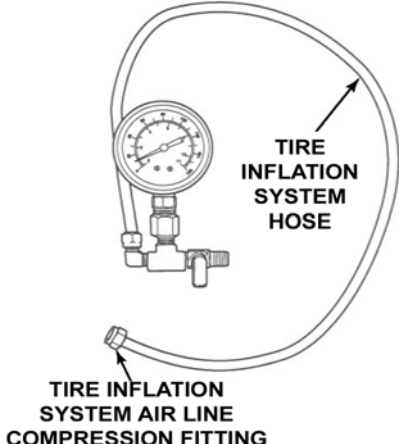
	Part Number	Description
	81044-00	Slide Hammer - Removes axle plugs and press plugs.
<p style="text-align: center;">Photo Not Available At Time of Printing</p>	81044-01	Welsh Plug Removal Spear. Attaches to 81044-00.
<p style="text-align: center;">Photo Not Available At Time of Printing</p>	81044-02	Press Plug Remover. Attaches to 81044-00.
<p>CONTROL BOX CALIBRATION GAUGE</p> 	81014-00	System Pressure Test Gauge.

Additional MTIS Service and Specialty Tools available from Hi-Tec Trailer, Inc. (361-547-0661) including:

Solid Spindle Drill Jig **81023-00**

Tap Guide **81023-10**

Polishing and Bore Tools available from Grainger (See MM14P).

Meritor Tire Inflation System Parts List

Part Number	Description
<u>Spare Parts</u>	
31012-01	3/8" Hex Nipple, 2 pack
31042-00	90° 1/8"MNPT x 1/4"TBG
31083-03	In-Line (Parallel) Flow Switch *
31083-28	Control Box Lid w/Screws and Gasket
31114-00	Steel 1/8" Bulkhead/Check Valve
31163-00	1/4"TBG Union Tee
31182-75	Wiring Harness
31222-00	1/4" Cable Choke Seal
31272-01	MTIS Attention Label, 10 pack
31282-01	MTIS 1-800 Label, 10 pack
32261-00	MTIS Light Label (Single Pack)
<u>Hub Caps - MTIS Ready</u>	
31427-00	Stemco Hub Cap Version 4009 - Oil (Bolt-on)
31426-00	Stemco Hub Cap Version 4009 - Grease (Bolt-on)
31428-00	Stemco Hub Cap - Grease
31438-00	Stemco Hub Cap Version 4075 - Oil (Screw-on, Straight Spindle)
31436-00	Stemco Hub Cap Version 4075 - Grease (Screw-on, Straight Spindle)
31439-00	Stemco Hub Cap Version 4195 - Oil (Bolt-on, Straight Spindle)
31437-00	Stemco Hub Cap Version 4195 - Grease (Bolt-on, Straight Spindle)
32273-00	DD Hub Cap (5.50" Bolt-On) - Grease
32283-00	DD Hub Cap (5.50" Bolt-On) - Oil
32293-00	DD Hub Cap (Screw-On) - Grease
32295-00	DD Hub Cap (Screw-On) - Oil
32514-00	DD Hub Cap (6.75" Bolt-On) - Grease
32515-00	DD Hub Cap (6.75" Bolt-On) - Oil
<u>Wheel End Kits (Includes Plug, Stator, Thru-Tee, Hoses) for 17.50" and Larger</u>	
31924-03	Dana/Eaton V3 and V4
31935-03	Ingersol F22, Hendrickson HN
31955-03	Holland Propar
31964-03	Meritor TN/TQ, HN, D22 Hollow
32375-03	Holland Trade
32405-03	Meritor TB (2.95")
32595-03	Sudisa 12-R
32645-03	Sudisa 11-M
32815-03	Dana P22, Hendrickson HP

Part Number	Description
<u>Spare Parts - Wheel Ends</u>	
31482-01	12-R Press Plug O-Ring (328), 3 pack
31492-01	O-Ring (small 020), 10 pack
32184-01A	TP Press Plug Kit with O-Ring
32202-01A	1.75" Press Plug Kit with O-Ring
32251-01	O-Ring (large 324), 3 pack
32321-01A	Propar Press Plug Kit with O-Ring
32342-01A	1.86" Holland Trade Press Plug Kit
32352-01	1.86" Press Plug O-Ring (223), 3 pack
32382-01A	2.95" Press Plug Kit with O-Ring used in Meritor TB Axles with Large Spindle Bore
32472-01A	2.50" Hendrickson HP Press Plug Kit
32473-01A	2.50" Press Plug Kit with O-Ring used in Dana P22, Hendrickson HP
32491-01	HP Plug O-Ring (330), 3 pack
32601-01A	2.25" 12-R Sudisa Press Plug Kit
32611-01A	1.50" 11-M Sudisa Press Plug Kit
32651-01	11-M Press Plug O-Ring (218), 3 pack
32671-01	TP Press Plug O-Ring (230), 3 pack
32701-01A	1.50" Ingersol F22 Press Plug Kit
32721-01	O-Ring (217) F22 Ingersol, 3 pack
<u>Drive Handle and Drivers (For Installation of Press Plugs into Axle Spindles)</u>	
51011-00	Drive Handle
51011-01	Driver - Holland Propar
51011-02	Driver - Meritor TN/TQ, RN/RQ, Hendrickson HN, Dana/Eaton D22 Hollow Spindle
51011-03	Driver - Sudisa 12-R
51011-04	Driver - Sudisa 11-M
51011-05	Driver - Holland Trade
51011-06	Driver - Meritor TP/TB
51011-07	Driver - Meritor WP
51011-08	Driver - Ingersol F22
51011-09	Driver - Sudisa 9-M
51011-10	Drive Handle
51011-11	Driver - Hendrickson Propar (2.50")
51011-13	Driver - Dana P22
51011-14	Driver - Meritor TB (2.95" Oversized Bore)

* Not interchangeable. Change effective January 2000.

Meritor Tire Inflation System Parts List (Continued)

Part Number	Description
Retrofit Kits	
31924-11	Dana/Eaton D22 Solid Spindle, Single Axle
31924-22	Dana/Eaton D22 Solid Spindle, Tandem Axle
31924-33	Dana/Eaton D22 Solid Spindle, Tri-Axle
31935-11	Ingersol F22, Single Axle
31935-22	Ingersol F22, Tandem Axle
31935-33	Ingersol F22, Tri-Axle
31955-11	Holland Propar, Single Axle
31955-22	Holland Propar, Tandem Axle
31955-33	Holland Propar, Tri-Axle
31965-11	Meritor TN/TQ, RN/RQ, Hendrickson HN, Dana/Eaton D22 Hollow Spindle, Single Axle
31965-22	Meritor TN/TQ, RN/RQ, Hendrickson HN, Dana/Eaton D22 Hollow Spindle, Tandem Axle
31965-33	Meritor TN/TQ, RN/RQ, Hendrickson HN, Dana/Eaton D22 Hollow Spindle, Tri-Axle
31975-11	Meritor TP, TB (1998 and later), WP, Single Axle
31975-22	Meritor TP, TB (1998 and later), WP, Tandem Axle
31975-33	Meritor TP, TB (1998 and later), WP, Tri-Axle
32375-11	Holland Trade, Single Axle
32375-22	Holland Trade, Tandem Axle
32375-33	Holland Trade, Tri-Axle
32405-11	Meritor TB (before 1998), Single Axle
32405-22	Meritor TB (before 1998), Tandem Axle
32405-33	Meritor TB (before 1998), Tri-Axle

Part Number	Description
Retrofit Kits (Continued)	
32595-11	Sudisa 12-R, Single Axle
32595-22	Sudisa 12-R, Tandem Axle
32595-33	Sudisa 12-R, Tri-Axle
32645-11	Sudisa 11-M, Single Axle
32645-22	Sudisa 11-M, Tandem Axle
32645-33	Sudisa 11-M, Tri-Axle
32712-11	MTIS Prepped Single Axle
32712-22	MTIS Prepped Tandem Axle
32712-33	MTIS Prepped Tri- Axle
32815-11	Dana P22, Hendrickson HP, Single Axle
32815-22	Dana P22, Hendrickson HP, Tandem Axle
32815-33	Dana P22, Hendrickson HP, Tri-Axle
H1965-11	ThermAlert for Meritor TN/TQ, RN/RQ, Hendrickson HN, Dana/Eaton D22 Hollow Spindle, Single Axle
H1965-22	ThermAlert for Meritor TN/TQ, RN/RQ, Hendrickson HN, Dana/Eaton D22 Hollow Spindle, Tandem Axle
H1965-33	ThermAlert for Meritor TN/TQ, RN/RQ, Hendrickson HN, Dana/Eaton D22 Hollow Spindle, Tri-Axle
H1975-11	ThermAlert for Meritor TP, TB (1998 and later), WP, Single Axle
H1975-22	ThermAlert for Meritor TP, TB (1998 and later), WP, Tandem Axle
H1975-33	ThermAlert for Meritor TP, TB (1998 and later), WP, Tri-Axle
Update Kits	
32083-00	Meritor TN, TQ, Hendrickson HN, Dana/Eaton D22 Hollow Spindle
32093-00	Meritor TP, TB (1998 and later), Hendrickson HP (2.75")

NEED MAINTENANCE INFORMATION?

MERITOR TIRE INFLATION SYSTEM

Installation and Maintenance Manual No. 14P

Numerical Parts Listing

Part Number	Page
31012-01	9
31023-01	4
31042-00	9
31052-35	4
31082-00	4
31083-02	4
31083-03	9
31083-09	4
31083-28	4, 9
31084-10	4
31103-00	4
31114-00	4, 9
31163-00	9
31182-75	9
31222-00	9
31263-03	4
31263-06	4
31263-08	4
31263-14	4
31263-15	4
31263-16	4
31272-01	9
31282-01	9
31314-21	5
31317-00	5
31317-00-S	5
31317-03	5
31317-03-S	5
31317-04	5
31317-04-S	5
31363-00	6
31364-00	6
31373-00	6
31374-00	6
31426-00	7, 9
31427-00	7, 9
31428-00	7, 9
31436-00	7, 9
31437-00	7, 9
31438-00	7, 9
31439-00	7, 9
31482-01	9
31492-01	9
31924-03	9
31924-11	10
31924-22	10
31924-33	10

Part Number	Page
31935-03	9
31935-11	10
31935-22	10
31935-33	10
31955-03	9
31955-11	10
31955-22	10
31955-33	10
31964-03	9
31965-11	10
31965-22	10
31965-33	10
31975-11	10
31975-22	10
31975-33	10
31982-01	6
32083-00	10
32093-00	10
32184-01A	6, 9
32202-01A	6, 9
32251-01	9
32261-00	9
32273-00	7, 9
32283-00	7, 9
32293-00	7, 9
32295-00	7, 9
32321-01A	6, 9
32342-01A	6, 9
32352-01	9
32375-03	9
32375-11	10
32375-22	10
32375-33	10
32382-01A	6, 9
32405-03	9
32405-11	10
32405-22	10
32405-33	10
32472-01A	9
32473-01A	6, 9
32491-01	9
32514-00	7, 9
32515-00	7, 9
32595-03	9
32595-11	10
32595-22	10
32595-33	10

Part Number	Page
32601-01A	6, 9
32611-01A	6, 9
32645-03	9
32645-11	10
32645-22	10
32645-33	10
32651-01	9
32671-01	9
32701-01A	6, 9
32712-11	10
32712-22	10
32712-33	10
32721-01	9
32771-01	6
32815-03	9
32815-11	10
32815-22	10
32815-33	10
51011-00	9
51011-01	9
51011-02	9
51011-03	9
51011-04	9
51011-05	9
51011-06	9
51011-07	9
51011-08	9
51011-09	9
51011-10	9
51011-11	9
51011-13	9
51011-14	9
61021-01A	6
81014-00	8
81023-00	8
81023-10	8
81044-00	8
81044-01	8
81044-02	8
H1965-11	10
H1965-22	10
H1965-33	10
H1975-11	10
H1975-22	10
H1975-33	10
H2200-02	6



MERITOR®

Meritor Heavy Vehicle Systems, LLC
7975 Dixie Highway
Florence, Kentucky 41042 USA

For more information:

U.S. 888-725-9355

Canada 800-387-3889

XpresswayPlus.meritor.com

meritor.com